

Miscellaneous**THE DIAGNOSIS BY ABDUCTION USING HUMAN
EXPERT KNOWLEDGE**

*Professor Viorel Ariton, PhD
Research Assistant Eng. Florin Postolache, PhD in progress
„Danubius”University from Galați*

Abstract: *Fault Diagnosis in real systems usually involves human expert's shallow knowledge (as pattern causes-effects) but also deep knowledge (as structural / functional modularization and models on behavior). The paper proposes a unified approach on diagnosis by abduction based on plausibility and relevance criteria multiple applied, in a connectionist implementation. Then, it focuses elicitation of deep knowledge on target conductive flow systems – most encountered in industry and not only, in the aim of fault diagnosis. Finally, the paper gives hints on design and building of diagnosis system by abduction, embedding deep and shallow knowledge (according to case) and performing hierarchical fault isolation, along with a case study on a hydraulic installation in a rolling mill plant.*

Keywords: *Faulty Diagnosis, abduction, plausibility criteria, relevant criterion*

Jel Classification: *Other Special Topics*

1. INTRODUCTION

Real systems are so complex that someone's efforts on detailed modeling fail. So, diagnosis (in technical, medical or economical domains) performed by human diagnosticians, often relies on incomplete, imprecise and uncertain knowledge. Human experts think in terms of *discrete* pieces: events, modules, causes and effects - all as separate knowledge pieces. Human concepts are also

qualitative – regarding relations between causes and effects. Designers and practitioners cope with complexity of real systems by means of physical, functional and behavioral units.

Diagnostic problem solving is abductive problem solving; human diagnostician's way involves shallow knowledge – regarding associations between causes and effects from practice, and deep knowledge – regarding causal links from laws in the domain.

The paper proposes a unified model for diagnosis by abduction with straight forward connectionist implementation, able to embed deep and shallow knowledge of human experts on the target system's faulty behavior, again computational issues included. The study that follows integrates concepts from means-end and bond-graphs modeling, in the effort to embed deep and shallow knowledge in a diagnosis system based on abduction.

2 UNIFIED MODEL FOR DIAGNOSIS BY ABDUCTION

Abduction means finding causes as explanation of effects observed in the target system. This chapter proposes a unified model for diagnosis by abduction, based on *plausibility* of causes from effects and *relevance* of causes. Plausibility embeds shallow and deep knowledge on cause-effects relations, relevance embeds deep knowledge on causes, related to physical and functional structures and to behavioral aspects of the target system.

2.1 Characteristics of abductive problem solving

Abductive reasoning in fault diagnosis considers the *cause* as single or multiple fault explaining *effects* appeared and observed by instance manifestations. Diagnosis in real systems faces a huge number of causes, due to various sources (equipment, environment human operator) and to various combinations of faults. On the other hand, the effects-to-faults links are complicated, while effects may enter, for example, conjunction or disjunction grouping when evoking faults, also interaction between causes when provoking some effects. [5] proposes four categories of abduction problems:

- *independent* abduction problems - no interaction exists between causes;
- *monotonic* abduction problems - an effect appears if cumulative causes appear;

- *incompatibility* abduction problems – pair of causes are mutually exclusive;
- *cancellation* abduction problems – pair of causes cancel some effect, otherwise explained separately.

[4] has a sound approach on abductive problem solving based on neural networks adapted to abductions problems above. They introduced a fifth category:

- open abduction problems - when observations consist of three sets: present, absent and unknown observations.

Human diagnostician usually master target systems structure and behavior complexity dealing with discrete pieces of knowledge: modules and components on physical structure, then process ends and component roles on functional structure. Regarding diagnosis, he or she employs other discrete pieces – faults and manifestations, which have truth values attached and refer to physical and functional units in a qualitative manner.

Various links between effects and causes (as reversed causal relation) commonly get a connectionist computational model, suited to abduction. Diagnosis applications meant for real complex systems exploits the great number of effects-to-faults patterns, obtained from human diagnostician's practice or from experiments, and embeds that shallow knowledge by training artificial neural networks. Deep knowledge – on causes and effects as in abduction problems above, may enter various dedicated processing (as in [4]).

2.2 Abductive problems solving by plausibility and relevance

Direct relations between effects and causes represent *plausibility criteria* [5]. From the set of all plausible causes only a subset represent actual causes, usually obtained through a parsimonious principle. [6] considers the minimum cardinality as a *relevance criterion* and applies it to the set of plausible faults to obtain the diagnostic subset.

2.2.1 Cause isolation by relevance

Plausibility criteria detects causes (e.g. faults), while relevance criteria isolate them. The paper extends the concept of relevance and makes it effective in Fault Detection and Isolation (FDI).

Relevance assumes some grouping of causes followed by selection of most plausible item from the group (in [1] called *relevance group*). For example, all faults occurring at a physical component form a group, only one likely to be the cause of effects appeared. Following the minimum cardinality principle over the structure, if one fault is relevant there is a single fault diagnosis and if certain number of faults there is performed multiple fault diagnosis.

The concept of relevance is useful when fault diagnosis relies on expert's deep knowledge, when he or she applies different grouping criteria to faults according to deep knowledge in the domain. Hence, relevance is effective not only regarding the minimum cardinality principle over the structure but also regarding some phenomena happening in the target system and domain. For example, while relevance criterion over structure states "a component is unlikely to have more than one fault at a time", in conductive flow systems another relevance criterion may apply "leakage is unlikely to be caused by more than one fault at a time". Relevance involves first grouping causes, then selecting the most relevant by some processing – for example sorting causes by plausibility.

2.2.2. *Plausibility and relevance in a connectionist approach*

As a general idea, abductive problem solving proceeds by multiple applying the two functions:

- *Plausibility* ($P_CRITERIA$, $EFFECTS$) which output is the set of all plausible $CAUSES$, activated from instance $EFFECTS$ according to plausibility criteria $P_CRITERIA$;
- *Relevance* ($R_CRITERIA$, $CAUSES$) which output is a subset of $CAUSES$ from the set of the plausible ones, in groups and relevance criteria according to $R_CRITERIA$.

Various $P_CRITERIA$ and $R_CRITERIA$ may apply sequentially to effects and causes until a final set of $CAUSES$ have truth values of highest level achievable. If cardinality of the final set of $CAUSES$ is 1 then one deals with single fault diagnosis, else with multiple fault diagnosis.

In a computational model using Artificial Neural Networks (ANN) plausibility criteria get implemented in forward excitatory links from $EFFECTS$ to $CAUSES$ and relevance criteria get implemented in competing links between $CAUSES$. In ANN implementation of diagnosis, both effects and faults get logical truth values, while in the incomplete and imprecise environment they may get following meanings: effects "almost" appeared, and causes "possibly" occurred.

Links between effects and causes enforce or reduce causes' truth values, toward the diagnostic – that is the set of most plausible and relevant causes.

However, ANN architecture must be adapted to comply with general types of abduction problems above, also to conjunction / disjunction grouping of effects to causes. In this respect, human diagnostician way of acting is again helpful, while plausibility and relevance get certain logical meanings from his or her point of view, as shown below.

2.2.3. *Characteristics of plausibility and relevance*

When activating causes from actual effects plausibility criteria should exhibit *qualitative* and *logical* features, for example when activating causes even their effects are not certain (i.e. as long as effects truth value grows, the cause truth value grows), or when cause activation depends on conjunction of some effects. Relevance criteria should exhibit *quantitative* features, while causes have to be compared to select the relevant one. In the computational model for abductive problem solving:

- plausible causes result from qualitative or logical processing that activate all causes from given set of effects;
- relevant causes result from quantitative processing that selects causes from the plausible set if exhibit a given certainty degree (greater than the threshold value).

While computational model deals with numbers, the two criteria should handle them adequately: numbers involved in plausibility criteria should suffer “*logical overload*” to allow conjunction / disjunction of effects to causes (and between causes) and numbers involved in relevance criteria assess the *degree* causes may belong to the diagnostic set.

The “logical overload” of numbers is a meaning attached to a range of values, similar to fuzzy truth values attached to elements in fuzzy subsets. Cardinality of partition, over the universe of discourse of a numerical variable V , may take the values: 2 – if processing refers to classical logical approach (truth values 0 and 1), 3 or more – if processing refers to Lukasiewicz or to Zadeh logic, depending on horizontal (α -cuts) or vertical (continuous) representation of the fuzzy subsets.

An example of logical overload of numbers is the following: if the input of a fault-neuron from a manifestation-neuron is greater than 0.5 (doubt threshold) then

the link is declared as “important” and enters the fault neuron (added to the other inputs), else it is “not important” hence blocked (set to 0).

2.3. Connectionist model of abduction by plausibility and relevance

In the presented approach, the ANN architecture for abductive problem solving is not a particular one; the only restrictions that apply are: the two layers *EFFECTS* and *CAUSES* are neighbour causes (because of possible conjunctions of effects to a fault – see §2.3.1). Plausibility criteria are forward links between *EFFECTS* and *CAUSES*, relevance criteria form various grouping of *CAUSES* then provoke competitions inside the relevance group. ANN architecture as Adaline, Perceptron or Counterpropagation, etc. are suited to implement the presented approach on abduction.

2.3.1 Neural models of plausibility

Let consider a cause C_i as a neuron that observes general equation for neuron activation by forward excitatory link from the layer of effects E_j (see Figure 1. a):

$$C_i = f(\sum w_{ji} \cdot E_j + \theta) \quad (1)$$

If both cause and effects get truth values, i.e. $C_i \in [0,1]$ and effects $E_j \in [0,1]$, then a link with weight w enforces the cause truth value at some effects. Cause neuron truth value C_i indicates how plausible is that cause in the context of actual effects values E_j . However, the above equation should also comply to plausibility criteria where effects enter a conjunction first, then attack the neuron’s input.

In the presented approach, an input of cause-neuron get “logical overload” to allow logical processing (e.g. conjunction) required by plausibility criteria. After the training phase the weights w get certain values and the an actual input at cause neuron C_i in recall phase will be $I_{ij} = w_{ij} \cdot E_j$. If the effect is not certain ($E_j < 0.5$) then input is $I_{ij} \leq w_{ij}/2$, hence:

$$\text{if } I_{ij} > w_{ij}/2 \text{ then } I_{ij} = \text{“important” else } I_{ij} = \text{“not important”} \quad (2)$$

It is now possible to perform logical aggregation on effects and causes. Neural model of plausibility is the *site* that performs the aggregation of input effects as follows (see Figure 1):

- *disjunctive aggregation* – performed by default through cumulative processing of effects E at case-neuron input I :

$$I_i = \sum w_{ij} \cdot E_j. \quad (3)$$

- *conjunctive aggregation* – performed by the “*conjunction site*”, see Figure 1. a, and the truth table; output O of the site observes the rule:

$$\text{if } I_1 > w_1/2 \text{ AND } I_2 > w_2/2 \text{ then } O = I_1 + I_2 \text{ else } O = 0 \quad (4)$$

- *negation* – performed by the “*negation site*”, see Figure 1. b, and the truth table; output O of the site observes the rule:

$$O = w_1 - I_1 \quad (5)$$

The original architecture of ANN is changed by the sites added to cause-neurons that require logical aggregation.

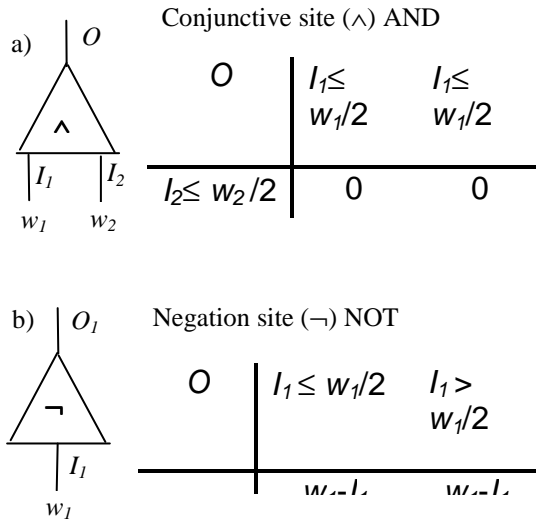

Figure 1. Neural sites for logical aggregation of effects to causes.

Note that added sites do not disturb or change the original running of the initial ANN, while they do not change either the training procedure or the values w of weights. For example, if two effects enter a conjunction aggregation, the input pattern for training such situation presents the two inputs with truth values greater than doubt value (0.5), while that pattern comply the real situation (both input effects are important); at recall phase it worth to activate the fault only if both actual effects are important.

2.3.2 Neural models for abduction problems

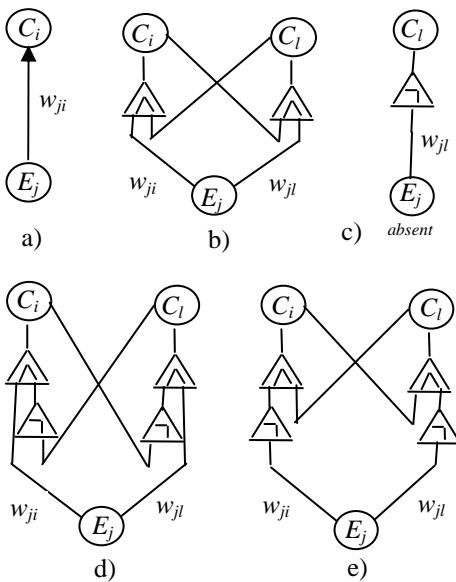

Figure 2. Abduction problem solving using neural network models for plausibility criteria

Neural (sites) models for the five abduction problems in the literature are depicted in Figure 2. and solve each category from §2.1 as follows:

a) For *independent* abduction problems – excitatory links apply directly from effect E_j to corresponding cause C_i (see Figure 2. a. If there exist also conjunction grouping of effects to the cause, conjunction site(s) get “mounted” and entering the default disjunctive grouping to neuron input.

b) For *monotonic* abduction problems – causes C_i and C_l evoking both the same effect E_j , suffer conjunction with one-another and with the common effect through conjunction sites as in Figure 2. b:

$$(C_i \leftarrow C_l \text{ AND } E_j) \text{ AND } (C_l \leftarrow C_i \text{ AND } E_j) \quad (6)$$

c) For *incompatibility* abduction problems – the pair C_i and C_l of causes are mutually exclusive, i.e. one is active if the other one is not, both evoking the same effect E_j . The pair of causes suffers conjunction with negation of another one conjunction with the common effect as in Figure 2. d:

$$(C_i \leftarrow \text{NOT } C_l \text{ AND } E_j) \text{ AND } (C_l \leftarrow \text{NOT } C_i \text{ AND } E_j) \quad (7)$$

d) For *cancellation* abduction problems – the pair C_i and C_l of causes are mutually exclusive, i.e. one is active if the other one is not, both evoking the same effect E_j . The pair of causes suffers conjunction with negation of another one conjunction with the common effect as in Figure 2. e:

$$(C_i \leftarrow \text{NOT } C_l \text{ AND } E_j) \text{ AND } (C_l \leftarrow \text{NOT } C_i \text{ AND } E_j) \quad (8)$$

e) For *open* abduction problems – the only problem is dealing with absent effects: cause C_i is activated if no effect E_j exists, see Figure 2. c:

$$C_i \leftarrow \text{NOT } E_j \quad (9)$$

Original ANN architecture for abductive problem solving is changed adding sites specific to each abduction problem, adequate to causes and effects in concern. However, similar to final note at §2.3.1, the ANN running is not changed – regarding the training procedure and values of weights obtained.

2.3.3 Neural models of relevance

A relevance criterion usually observes minimal cardinality of *CAUSES* over criterion's specific relevance group. In general, relevance involves three stage processing:

- i) Consider all plausible causes belonging to relevance group.
- ii) Start competition between causes inside relevance group.
- iii) Select cause(s) for diagnostic set, observing an ordinal property of causes and some selection threshold.

Neural model of relevance is competition between causes. Computationally, it may consist from sorting all causes in the relevance group, then selecting the one(s) with higher degree according to a maximum number (e.g. 1 if single fault diagnosis), or a “relevance value” (e.g. minimum activation of causes – if they exceed the doubt value 0.5). For example, if the ordinal property for sorting is plausibility of causes (truth values of *CAUSES*), then the sorting procedure is applied to all causes in the relevance group - not only to plausible ones, while those not plausible have the lowest degree. So, competition proceeds always over the entire set of *CAUSES* in the relevance group.

3 DEEP AND SHALLOW KNOWLEDGE IN DIAGNOSIS

Knowledge elicitation is a very important phase in diagnosis system design, while it involves information on various causes and effects, on physical structure and on normal and faulty behavior of the target system in real life. Any approach on diagnosis depends on how knowledge covers spaces of causes, effects and their relations; otherwise, one gets open spaces and incomplete knowledge leads to inaccurate diagnosis. When the target system is a *conductive flow system* (CFS) diagnosis is more difficult due to propagated effects throughout the system.

Few works refer to methodical procedures to guide knowledge elicitation, and fewer to generic models suited to control and guide knowledge covering for diagnosis purposes. [3] proposes knowledge pieces suited to cover faulty behavior of CFSs based on means-end modeling approach and bond graphs, and [2] presents a CAKE (Computer Aided Knowledge Elicitation) tool for methodical covering of structural and behavioral complexity of a target CFS.

Present chapter stresses main directions to extract deep knowledge on structure and behavior of conductive flow systems which perform simultaneously multiple functions – further denominated *Multifunctional Conductive Flow Systems* (MCFSS), and the ways such knowledge is represented and become plausibility and relevance criteria for diagnosis by abduction.

3.1 Abstraction levels for structure and behavior

It is commonly accepted that discrete pieces in physical and functional structure of a real target system is only an abstraction that requires also models for continuous behavior; the entire model obtained is a *hybrid dynamic model* (as discussed in [7]). In this view, deep knowledge on the target MCFS refers to:

- physical and functional units, from means-end modeling perspective – as Discrete Event System abstraction;
- bond graph components and junctions, from bond graph modeling perspective – as Continuous System abstraction required to assess abnormal behavior of structural units.

For CFSs bond graphs represent powerful modeling means, as they not only capture essential ideas from Kirchhoff’s laws but, additionally, offer a proper modularization of the target system’s model, in a general conceptualization.

3.1.1 *Physical and functional structure*

From means-end point of view the *module* is a network of *components*, and the entire target *MCFS* is a network of modules. Modules accomplish specific *ends* during specific *activities* through components *flow functions* as in [8]. Each module may accomplish more ends, provided one end attained during one activity; each components may have more functions but only one during one activity of the superset module.

From bond graph point of view, modules correspond to bond graph junctions. [3] proposes three generic flow functions that correspond to bond graph primitive components, so reducing them to a meaningful subset for diagnosis purposes:

- flow transport function (*ftf*) – *R* component; when faulty, directly affects propagation of power flow along paths in the target CFS;
- flow storing function (*fsf*) – *C* and *I* components; when faulty, directly affect time delays in the running process;
- flow processing function (*fpf*) – *TR* and *GY* components; when faulty, directly affect the ends of modules.

3.1.2 *Faulty behavior structure*

Fault is a physical non-conformity occurred at component level, opposed to designed specifications from producer. Fault’s name often suggests a disorder or a physical damage so, it reflects knowledge incompleteness about component structure. The set of all “known” faults should be decided at elicitation phase; some of them indicate a specific damage, some – a class of damages.

Manifestation is a piece of knowledge assessing values of an observed variable at component, during a certain activity of the superset module. Manifestation is a linguistic variable with truth values for normal (*no*) or “too low”

(*lo*), “too high” (*hi*) linguistic values. Some manifestations arrive by sensors (from continuous or binary variables), some by human operators tests (from human senses – as adjectives, or from test points – as numbers) on observed variables in the process. Manifestations may refer to primary effects or to secondary effects.

Anomaly or symptom is a piece of knowledge obtained from a set of manifestation by some processing, and deposits deep knowledge in the domain, so helpful in diagnosis (see below).

3.1.3 *Generic anomalies in the faulty behavior*

To each generic flow function a generic anomaly is attached:

- i) *Process anomaly* (AnoP) – means deviation from the normal value (e.g. “too high” or “too low”) of an end-variable; it refers to transformations the flow undergoes.
- ii) *Transport anomaly* (AnoT) - means changes on flow variables or on inner structure of component, relative to flow transport along flow paths.
- iii) *Store anomaly* (AnoS) – refers to deviation from the normal value for the delay specific to storing (capacitor-like) or inertial (inductance-like) component (see §2.3.).

Note that only transport anomalies refer to propagated effects, while process and store anomalies are located at component showing corresponding flow function *fpf* or *fsf* as above. If there is a definite set of transport anomalies located at faulty component, then they get meanings of primary effects.

[3] presents signatures with manifestations at effort and flow (bond graph) variables in 1-junction and 0-junction, specific to transport anomaly occurred in the junction.

3.1.4 *Orthogonal transport anomalies*

It works on fault diagnosis deal with concepts as “leakage” or “obstruction”. [3] defines a set of four orthogonal transport-anomalies for bond graph components, as follows:

- a) *Obstruction* – change of resistance parameter (increase), without flow path modification, e.g. clogged pipe.
- b) *Tunneling* – change of resistance parameter (decrease), without flow path modification, e.g. broken-through pipe.

- c) *Leakage* – structure change (balance too low on flow), involving flow path modification, e.g. whole in pipe.
- d) *Infiltration* – structure change (balance too high on flow), involving flow path modification, e.g. flow injection.

Transport anomalies are orthogonal in pairs (obstruction to tunneling and leakage to infiltration), each pair orthogonal to the other. A fault causes a unique transport anomaly that appears at respective component and, by default, at module it belongs. Thus, transport anomaly is a primary effect located at module level, hence isolating it means isolating the faulty module.

Each type of transport anomaly has a specific signature – regarding deviations for bond graph junctions.

3.2 Guidelines on knowledge embedding in plausibility and relevance criteria

The main problem raised on diagnosis by abduction in the proposed approach is deep and shallow knowledge elicitation and embedding in the neural network for diagnosis.

During elicitation phase, knowledge engineer discriminates:

- *physical structure* – i.e. modules and components;
- *functional structure* – i.e. activities for modules and flow functions for components, bond graph junctions for interconnected modules and bond graph components with specific parameters for corresponding flow functions;
- *behavioral structure* – i.e. faults, manifestations and flow anomalies (processing, store, transport).

Note that components result from hierarchical decomposition of physical structure according to the accepted granularity of fault isolation, that is location units for faults may also have structure.

Plausibility criteria embed shallow knowledge as patterns of non-propagated manifestations-to-faults (e.g. color, position) and anomalies-to-faults. Deep knowledge refers to conjunction and abduction problems related to manifestations and certain faults.

Relevance criteria involve modularization of faults according to deep knowledge on physical and functional structure and on anomalies they provoke (in the given structural unit).

It worth stressing that shallow knowledge for plausibility is obtained for each module separately. So, practical survey rather experiments on real complex systems seem realistic (in technical and economical domains), while they are much easier performed and less combinatorial burden occur than for the entire system.

3.3. Abduction procedure for diagnosis

All discrete concepts resulted from elicitation phase should enter in ANN structure for diagnosis by abduction. So, all units from behavioral structure become neurons: manifestations on input layer, faults on output layer and anomalies on an intermediate level (activated by manifestations and attacking faults). All behavioral units attached to a module belong to a separate neural network (ANN). Links between neurons get weights by training procedure (from shallow knowledge) and sites from deep knowledge, all according to plausibility criteria stated by human diagnostician at elicitation phase.

All units from physical and functional structures become relevance groups related to relevance criteria at elicitation phase.

For proper diagnosis, each component (as final location in fault isolation) have attached the “normal” *CAUSE*, beside all faults at component in concern. So, to the set F_0, F_1, \dots, F_{n-1} of neurons indicating faults, it is added the F_n neuron – assessing the truth value of normal running. It is important to exist a F_n neuron because *NORMAL* situation enters relevance competition with *FAULTY* situation. So, before finding the cause when faulty situation occurred, diagnosis system should asses if the target system is *FAULTY* (i.e. it performs fault detection).

To asses *FAULTY* situation a relevance criterion is applied over all decisions F_0 to F_{n-1} and F_n as follows:

$$\text{if } \exists F_i > 0.5 \text{ (} i = 1..n - 1 \text{)} \wedge \sum_{i=0}^{n-1} F_i > n \cdot F_n \text{ then } \textit{FAULTY} \text{ (10)}$$

in words: if any of activated faults have truth values greater than the “doubt value” and the relative level of the *NORMAL* situation is greater than all current (activated) faults, then the *FAULTY* situation is credited.

Diagnosis is performed in hierarchic and sequential manner, detecting transport anomaly at module, then isolating fault(s) by abduction through multiple plausibility and relevance criteria:

1) *faulty module isolation* – by plausibility and relevance of transport anomalies possibly occurred based on signatures in junctions of the system's bond graph model (see [2]);

2..n-1) *fault isolation* – proceed by sequential application of a given sets of plausibility and relevance criteria, specific to module detected in stage 1;

n) *diagnostic* – fault(s) obtained after assessing faulty situation versus normal situation at module, by relevance as in (10).

Because modules of target MCFS simultaneously accomplish ends (independent from one another), combinations of activities raise to a huge number. In the hierarchic way proposed, diagnosis relies only on shallow knowledge and deep knowledge at module level, then on groups of modules in bond graph junctions.

4 CASE STUDY ON A HYDRAULIC INSTALLATION

Fault diagnosis was meant for a simple hydraulic installation in a rolling mill plant (see Figure 3), comprising three modules: Supply Unit (pump, tank and pressure valve), Hydraulic Brake (control valve, brake cylinder) and Conveyor (control valve, self, the conveyor cylinder). For the 20 faults to 8 components considered, manifestations come from sensors as *lo*, *no*, *hi* values (2 flow-rate, 4 pressure, 5 temperature), 8 binary values (cylinders at left/right ends and open/shut valves) also 10 linguistic manifestations from operator observed variables (for noise and oil-mud). Software architecture exhibit 6 ANN perceptron blocks – 2 per module.

The three modules – corresponding to Hydraulic Brake, Carrier and Oil Supply, are all bond graph 1-junctions (if considering components on the loop for each) and they enter a 0-junction, corresponding to the entire hydraulic MCFS. Modules evolve (somehow) independently those with hydraulic cylinders in 4 activities and the third with 2 activities.

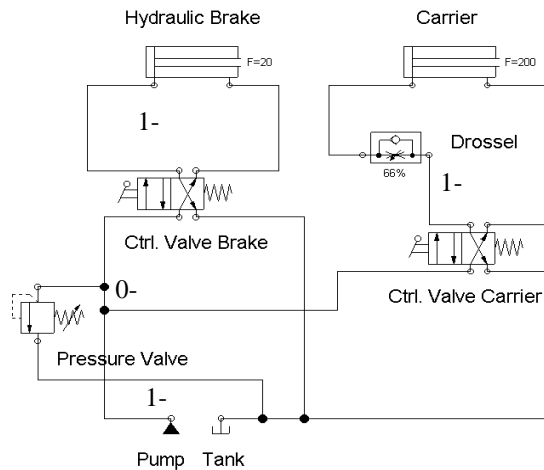

Figure 3. Hydraulic installation under fault diagnosis.

Figure 4 presents the diagnostic for 20 simulated faults in the example hydraulic installation and the maximum number of successive activities in which the diagnosis system is able to properly indicate the fault; additional observations supplied by human operator count as distinct activities.

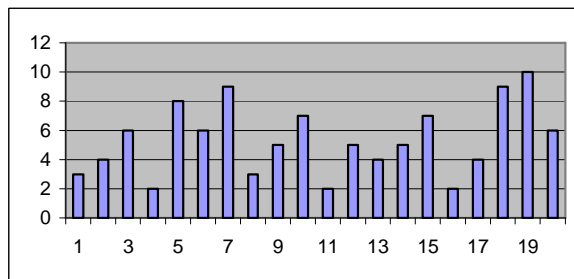

Figure 4. 20 faults and the number of activities in which they are properly recognized.

Diagnosis performed on the target hydraulic system applied plausibility criteria from human diagnostician concerning patterns of manifestations-to-faults from practice and deep knowledge on specific transport anomalies for the faults in concern. Deep knowledge for relevance criteria refer to physical structure and to transport anomalies shared by faults.

5 CONCLUSION

Diagnosis is a difficult task in real life, while it is often performed on open spaces of causes and effects, in an incomplete and imprecise knowledge milieu. Human diagnostician performs diagnosis by abduction; abductive reasoning itself is a challenge for philosophy, science and practice.

The paper proposes a unified model for diagnosis by abduction, based on plausibility and relevance criteria on causes. It allows connectionist implementation through various artificial neural network types – if adequate to implement plausibility by excitatory links between effects and causes, and relevance by competition in special groups of causes; all effects and causes become neurons with graded levels of truth – regarding evidence of effects and certainty of cause, respectively.

The unified model for diagnosis by abduction is simpler than the one proposed by [4], and offers also natural meanings for human diagnosticians interested on practical implementation in technical or economical domains.

The unified for abductive problem solving model is fully functional for all categories of abduction problems, also for disjunctive and conjunctive grouping of effects to a cause. It is meant to embed shallow and deep knowledge from human diagnostician in the way he or she actually does in practice and the connectionist model

The paper presents also hints on knowledge elicitation of deep and shallow knowledge on the class of multifunctional conductive flow systems (MCFSSs), i.e. systems that perform simultaneously multiple functions, based on (multiple) flow conduction. Such systems are often met in industry but also in other domains of real life. So, along with the diagnosis model by abduction the paper offers design guidelines for computational model of an automated diagnosis system. Application in simulated environment shows good performance, of diagnostic, however strongly dependent on available knowledge.

REFERENCES

1. Ariton, V., Ariton D., *A General Approach for Diagnostic Problems Solving by Abduction*, 4th IFAC Symposium on Fault Detection Supervision and Safety, Budapest, pp. 446-451;
2. Ariton, V., Baciuc, C., *Knowledge Elicitation And Case Tool For Fault Diagnosis In Multifunctional Conductive Flow Systems*, 5th World Multiconference on Systemics, Cybernetics and Informatics (SCI2002), Electronics, Informatics and Control Systems – Invited Session, Organizer: Volume XXII, Orlando, Florida, USA, 2002;
3. Ariton V., *Deep and shallow knowledge in fault diagnosis*, Lecture Notes in Artificial Intelligence LNAI 2773, Palade, V., Howlett, R. J., Lakhmi J. (Eds), Springer Verlag - 7th International Conference, KES2003, Oxford, UK, pp.748-755, 2003;
4. Ayeb B., Wang S., Ge J. (1998), *A Unified Model for Abduction-Based Reasoning*, IEEE Trans. on Syst. Man and Cybernetics - Part A: Systems and Humans, 28, no.4. 1998, pp.408-424;
5. Bylander T., Allemang D., Tanner M. C., Josephson J. R., (1991). *The computational complexity of abduction*, Artificial Intelligence 49, Elsevier 1991, pp. 25-60;
6. Konolige K. (1992). *Abduction versus closure in causal theories*, Artificial Intelligence, 53, Elsevier 1992, pp. 255-272;
7. Mosterman P.J. *Hybrid Dynamic Systems: A hybrid bond graph modeling paradigm and its application in diagnosis*, Ph.D. Thesis, Vanderbilt University, 1997;
8. Larsson, J. E., *Knowledge-based methods for control systems*, PhD Thesis Dissertation, Lund - Sweden, 1992.